

4S-700E

Mobile Offline Oil Filter System

- Stainless steel construction
- 4 microfiltration units SDU-H8 incl. 4 filter elements SDFC
- Filtration performance (average value) 480 l/h (40 cSt)
- For oil quantities up to 5000 litres
- Self-priming gear pump
- Large pre-filter unit with washable filter bag
- Intelligent PLC control
- Overpressure and run-dry protection with automatic switch-off
- Filter element change timer
- IP rating: IP 55
- Transfer function - for movement of the oil without filtration
- 6m suction and return hose with quick release couplings



Results

Water Removed



Removes free and dissolved water

Particles Removed

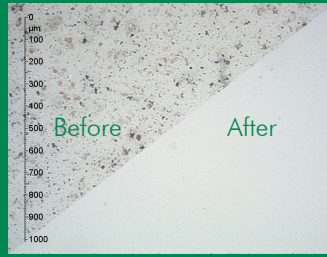

Achievable oil cleanliness / cleanliness class in the ideal case: 13/11/8 (ISO 4406: 1999) Class 2 (NAS 1638) - better than new oil quality levels

Benefits

- Removes varnish and microparticles down to 1 micron
- Removes free and dissolved water contamination
- Increases system reliability
- Prevents system corrosion (water!)
- Less component wear
- Extended oil change intervals; CO₂ -reduction
- Reduces operating costs
- Simple oil sample taking

Application Examples

This offline mobile filter system with the SDFC filter elements fitted as standard is suitable for filtration of mineral oil based and/or synthetic, non water-based lubricants and pressure fluids. This filter system is ideal for application in all service-workshops or manufacturing plants such as, e.g.:

- Power generation
- Plastic Moulding
- Cement industry
- Every kind of industry where oils are employed

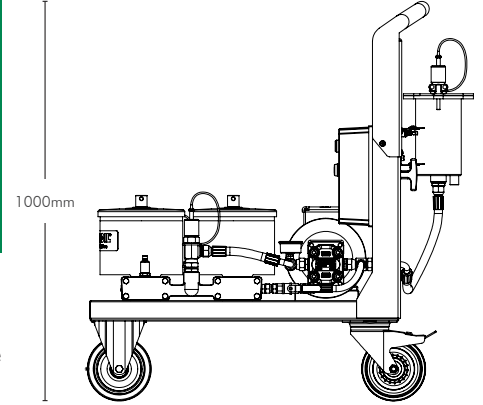
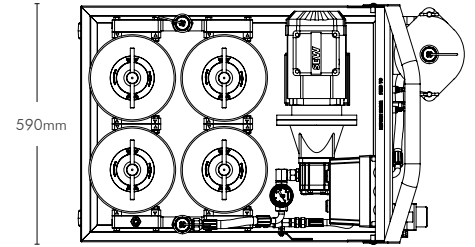

967mm

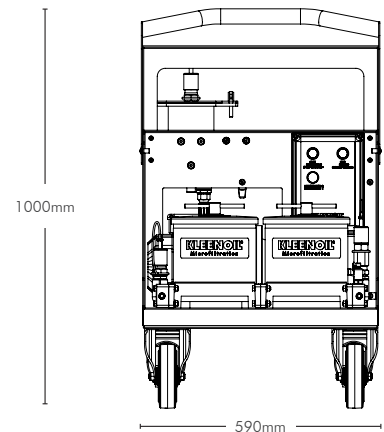

| Type | Recommended Installation | Max. Operating Temp. | IP Rating | Flow Rate (average value at < 40 cSt.) l/h | Pump Suction Lift | Voltage/ Motor performance/ Current Draw | Dimensions (mm) | | Weight (kg) | Filter Element Type | Retention Capacity per Element (x4) | |
|---------|---|----------------------|-----------|--|-----------------------|--|-----------------|-----|-------------|--|-------------------------------------|----------------|
| | | | | | | | H | W | | | Dirt: ≤ 2 kg | Water: ≤ 0.5 l |
| 4S-700E | Mobile offline filtration system: Installation Taking feed and return from hydraulic reservoir / tank. For systems up to 5.000 litres. | 60°C | IP55 | 500 | Self-priming to 5.5 m | 110 / 230 V 0,55 KW ≤ 8.5 / ≤ 4.0 Amps | 1000 | 590 | 95 | Standard fit: 4 x SDFC (oil based fluids) | ≤ 2 kg | ≤ 0.5 l |
| | | | | | | | L | | | | | |
| | | | | | | | 967 | | | | | |

KLEENOIL PANOLIN AG

Schnötring 2-3 79804 Dogern Deutschland
T. +49 7751 8383-0 F. +49 7751 8383-29 E. info@kleenoil.com
www.kleenoilpanolin.com

The specification and photography above is for reference only and may be subject to change.
KLEENOIL is a trademark of the company KLEENOIL PANOLIN AG. © KLEENOIL PANOLIN AG. All rights reserved.

KLEENOIL[®]
Microfiltration