

## 6S-E Mobile Offline Oil Filtration System

- Steel construction, powder coated
- 6 microfiltration units SDU-H8 incl. 6 filter elements SDFC
- Filtration performance (average value) 720 l/h (40 cSt)
- For oil quantities up to 10.000 litres
- Self-priming gear pump
- Large pre-filter unit with washable filter bag
- Intelligent PLC control with LCD display
- Automatic pressure regulation
- Overpressure and run-dry protection with automatic switch-off
- Integrated 2 kW pre-heater for filtration of cold / viscous oils
- Filter element change timer
- IP rating: IP 55
- Transfer function - movement of the oil without filtration
- 6m suction and return hose with quick release couplings
- Lifting points



## Results

### Water Removed



Removes free and dissolved water

### Particles Removed

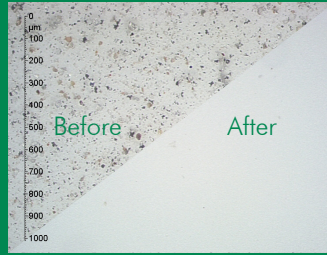

Oil cleanliness / cleanliness class in the ideal case:  
 13/11/8 (ISO 4406: 1999)  
 Class 2 (NAS 1638)  
 - better than new oil quality levels

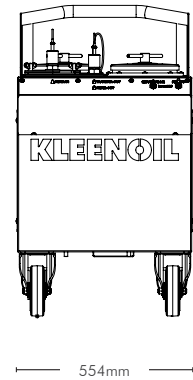
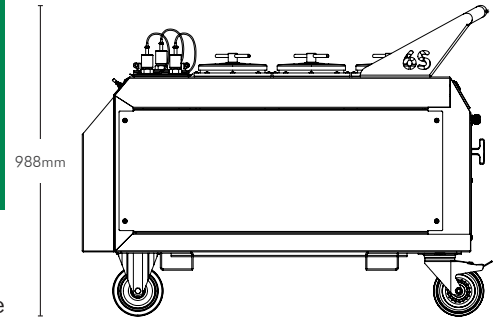
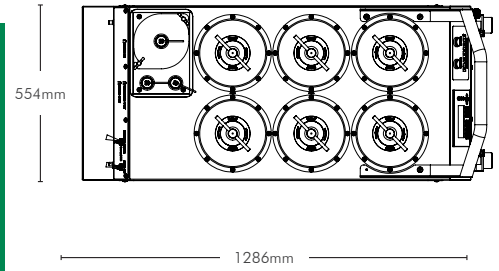

### Benefits

- Removes varnish and microparticles down to 1 micron
- Removes free and dissolved water contamination
- Increases system reliability
- Prevents system corrosion (water!)
- Reduces component wear
- Extended oil change intervals; CO<sub>2</sub> -reduction
- Reduced operating costs
- Simple oil sample taking

### Application Examples

This offline mobile filter system with the SDFC filter elements fitted as standard is suitable for filtration of mineral oil based and/or synthetic, non water-based lubricants and pressure fluids. This filter system is ideal for application in all service-workshops or manufacturing plants such as, e.g.:

- Power generation
- Plastic Moulding
- Cement industry
- Every kind of industry where oils are employed

Type	Recommended Installation	Max. Operating temp.	IP Rating	Flow rate (average value at < 40 cSt) (l/h)	Pump Suction Lift	Voltage/ Motor Performance/ Current Draw	Dimensions (mm)		Weight (kg)	Filter Element Type	Retention Capacity per Element (x6)	
							H	W			Dirt: ≤ 2 kg	Water: ≤ 0.5 l
6S-E	Mobile offline filter system Installation: taking feed and return from hydraulic reservoir / tank. For systems up to 10.000 litres.	60°C	IP55	720	Self-priming to 5.5 m	230 V 0,55 KW ≤ 12.5 Amps	988	554	155	Standard fit: 6 x SDFC (oil based fluids)	Dirt: ≤ 2 kg	Water: ≤ 0.5 l
							L					
							1286					

KLEENOIL PANOLIN AG

Schnörtring 2-3 79804 Dogern Deutschland

T. +49 7751 8383-0 F. +49 7751 8383-29 E. info@kleenoil.com

www.kleenoilpanolin.com

The specification and photography above is for reference only and may be subject to change.  
 KLEENOIL is a trademark of the company KLEENOIL PANOLIN AG. © KLEENOIL PANOLIN AG. All rights reserved.

**KLEENOIL**<sup>®</sup>  
 Microfiltration